

Mod./Type: **FORNI A CONVEZIONE E COMBINATI**  
**CONVECTION AND COMBINED OVENS**

cod./num. 2532298.00

data/date: 15/12/2015

_FDEKR 061 P...
_FDEKR 0623 P...
_FDEKR 101 P...

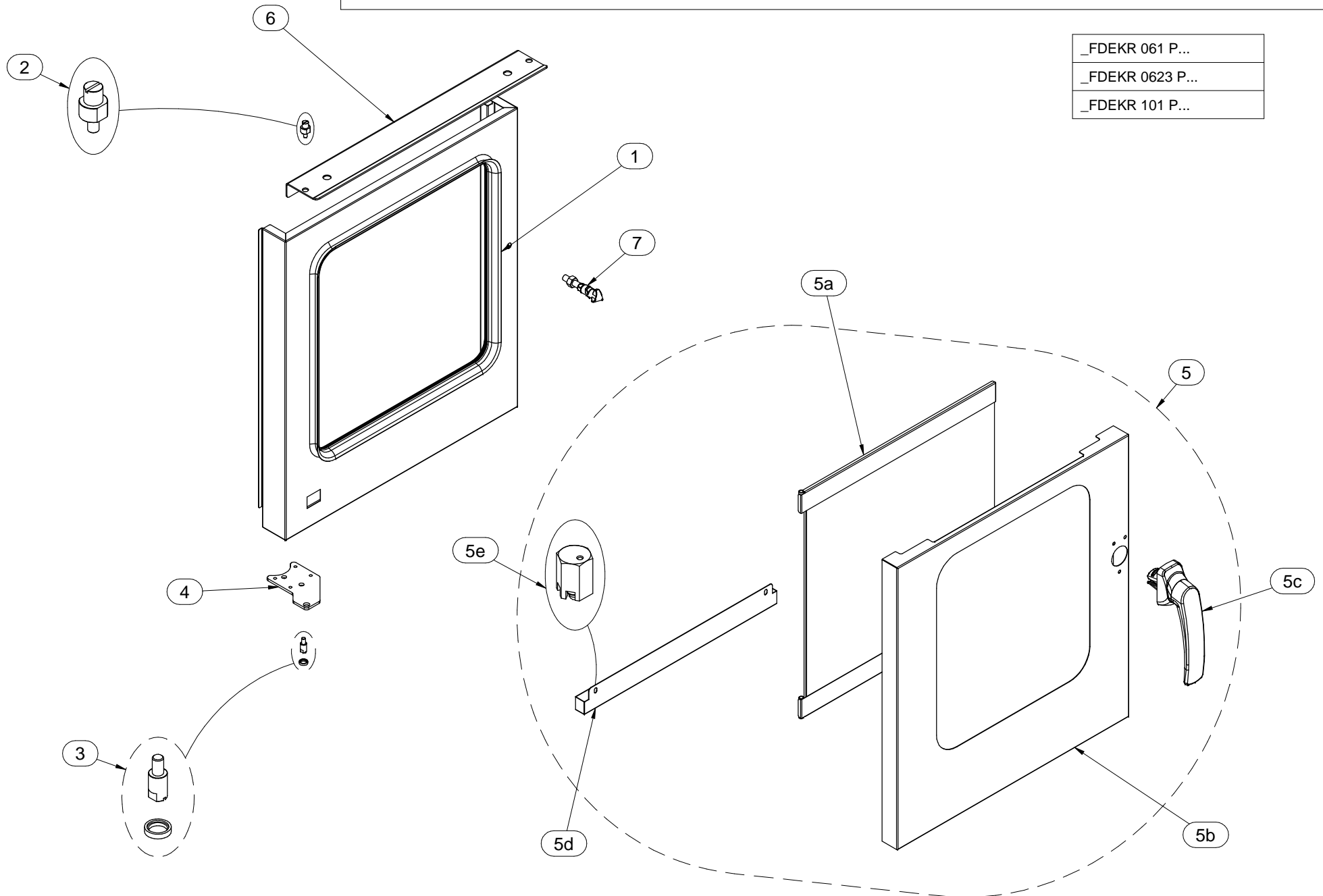



Mod./Type: **FORNI A CONVEZIONE E COMBINATI**  
**CONVECTION AND COMBINED OVENS**

cod./num. 2532300.00

data/date: 17/12/2015

_FDEK... 061 P...
_FDEK... 0623 P...
_FDEK... 101 P...

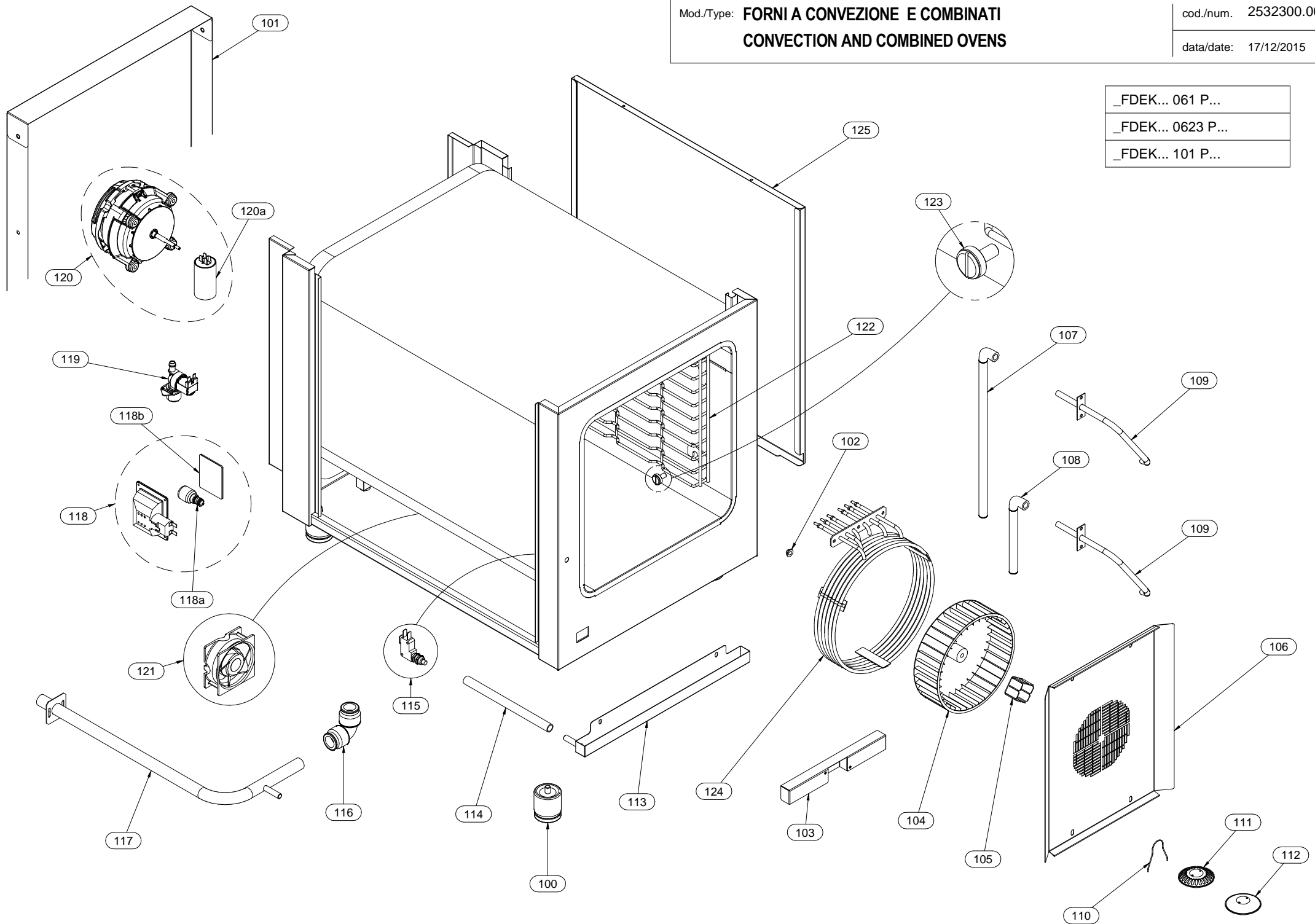



\_FDEK... 061 P...  
\_FDEK... 101 P...

Mod./Type: **FORNI A CONVEZIONE E COMBINATI**  
**CONVECTION AND COMBINED OVENS**

cod./num. 2532302.00

data/date: 18/12/2015

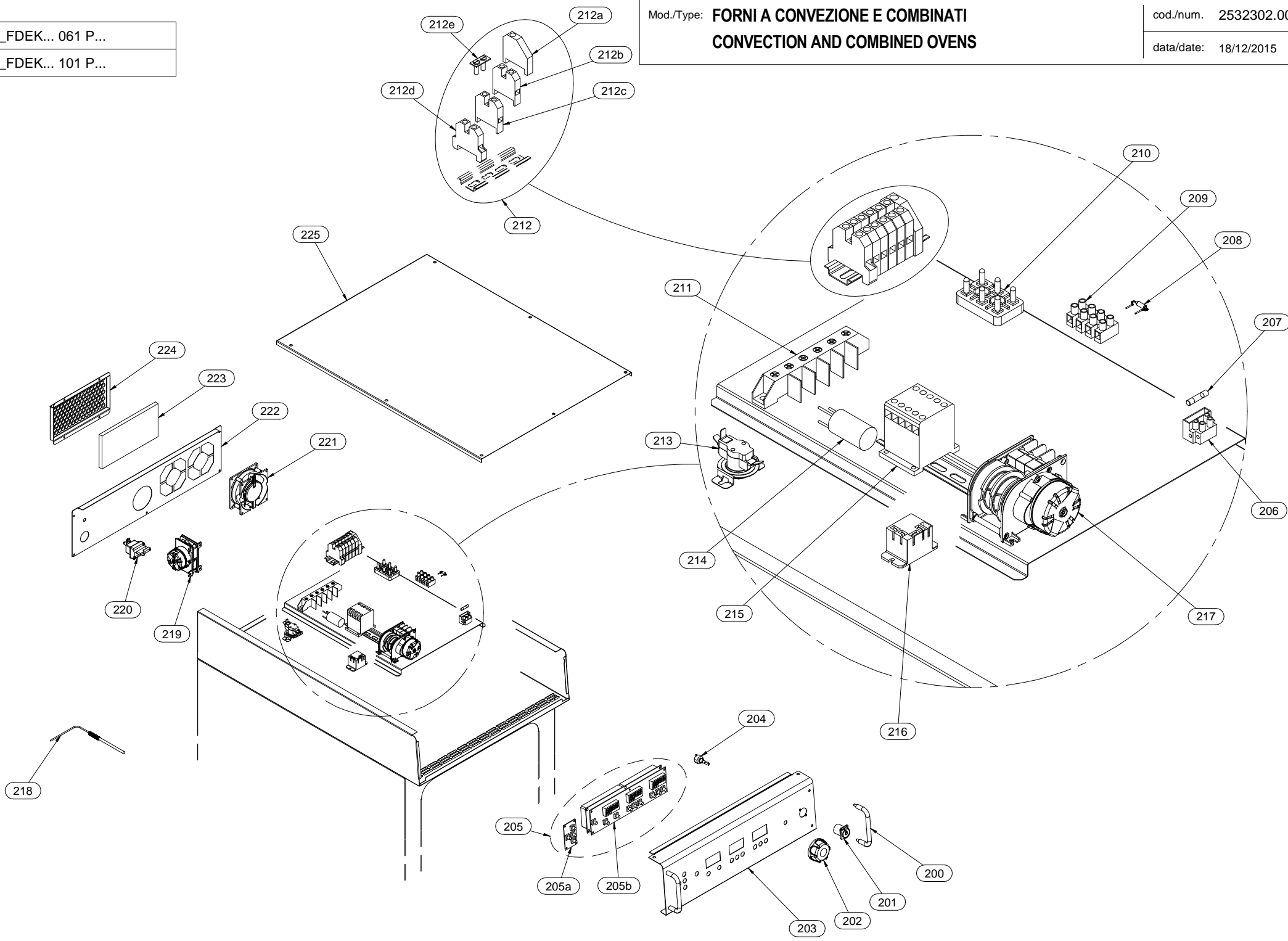



_FDEK... 0623 P WA
_FDEK... 061 P WA
_FDEK... 101 P WA

